

The antenna AD-10/S is a wideband vertical polarised dipole covering the frequency range from 108 to 512 MHz. All elements of the antenna are enclosed in an epoxy - glass composite tube. The antenna is intended for stationary use. Electrically the antenna is designed so that enables a large bandwidth and relatively constant vertical radiation diagram. The antenna has built-in a coaxial cable length of 1 m with coaxial connector N female type at the end. A special mounting tube with mounting console adapter enables to mount the antenna on the mast with diam. up to 60 mm (2").

Frequency range	108 - 512 MHz
Impedance	50 ohm
VSWR	< 2.5
Gain	-2...+2 dBi
Polarization	VER.
Maximum power	500 W CW
Connector	N female
Height	1100 mm
Diameter	130 mm
Mass of antenna	7,8 kg
Wind velocity	160 km/h
Temperature range	-55...+80 °C

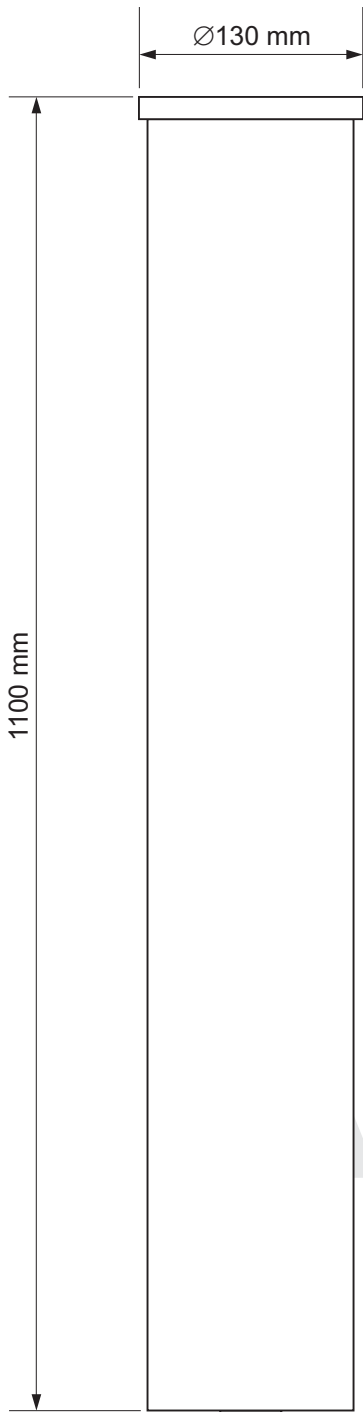



VSWR

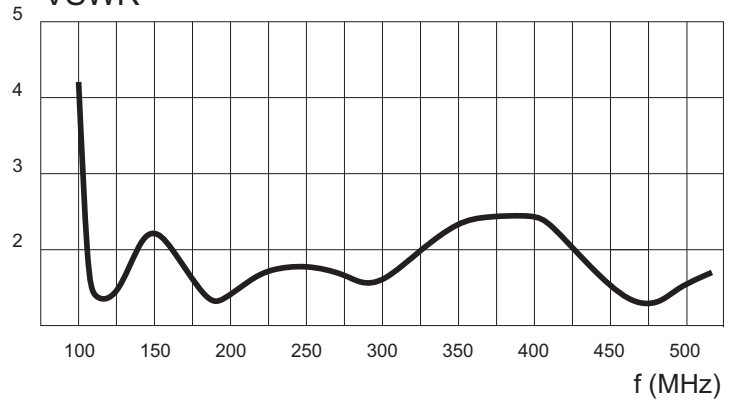

Gain (dBi)

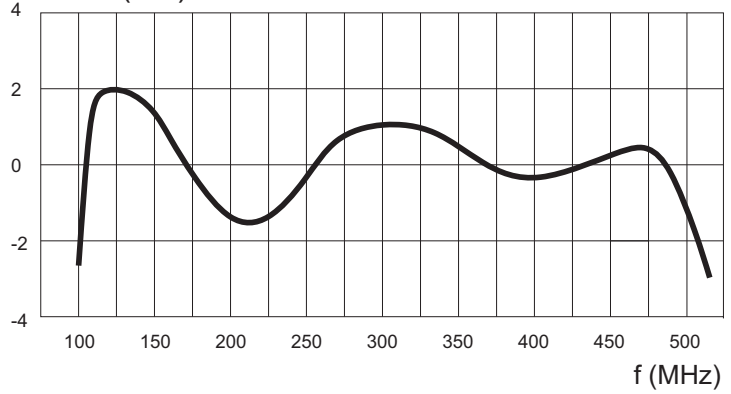

Radiation Pattern E-plane

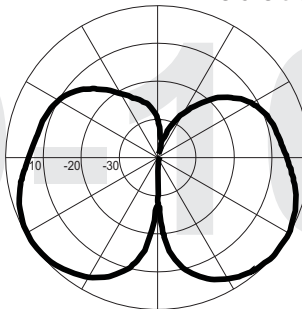

F = 100 MHz

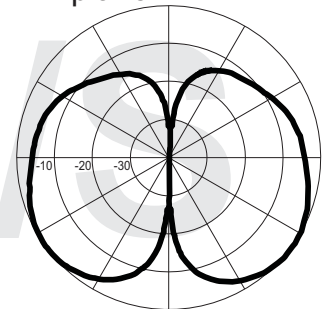

F = 200 MHz

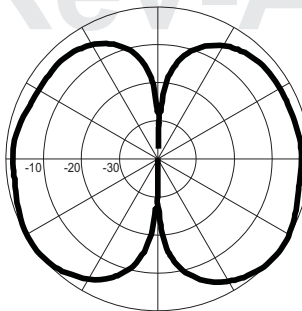

F = 300 MHz

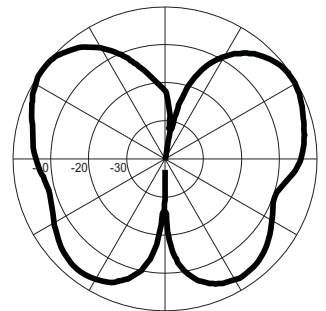

F = 400 MHz

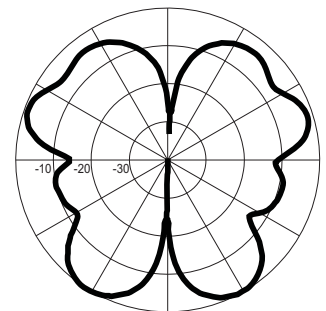

F = 500 MHz

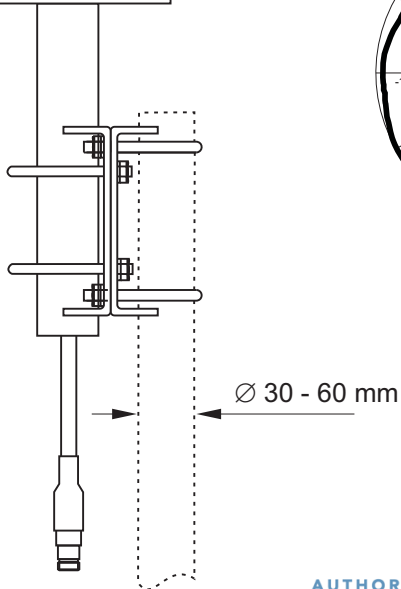

**AUTHORIZED USA DISTRIBUTION BY:**

Cyntony Corporation  
195 Follen Road  
Lexington, Massachusetts  
sales@cyntony.com  
781-430-0675

**cyntony**  
customer attuned